

1-2-3 KVCX SETS WITH 1-2-3 VERTICAL MULTISTAGE CENTRIFUGAL PUMPS

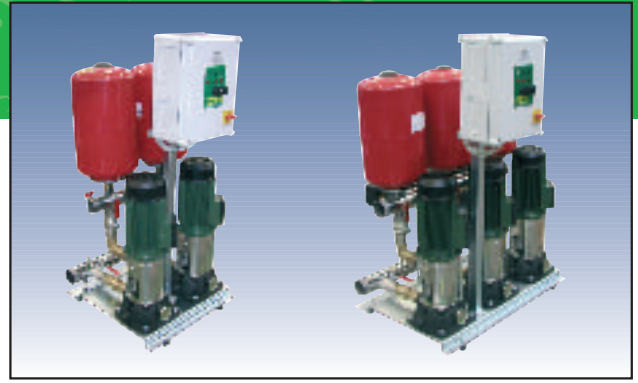

Booster set suitable for domestic use, small installations for civil, agricultural or industrial use. The use of vertically-mounted multistage centrifugal electric pumps ensures outstanding performance and elevated efficiency. They are particularly compact and strong, totally reliable and extremely silent-running.

CONSTRUCTIONAL CHARACTERISTICS:

Hydraulic part

- 1-2-3 Multistage KVCX electric pumps on a vertical axis;
- Galvanised steel plate complete with anti-vibration rubber feet
- Suction and delivery manifolds in stainless steel AISI 304 (1KVCX without suction manifolds);
- 1 - 2 - 3 Membrane tanks;
- Ball valves on the suction and delivery pipe union of each single pump
- Check valve on the suction pipe union of each pump;
- 1/4 " air connectors on suction side of each pump;
- 2 stainless steel female manifold caps;
- Axial pressure gauge with shut-off valve

- Galvanised steel column support for electrical panel

Electrical part

Control panel in shockproof fire-resistant plastic material, IP 55 protection level. The panel comprises a general switch, pump overload circuit breakers, starting order exchange system for pumps, 24 v low voltage circuit for control pressure switches, MAN -0-AUT selectors. (start buttons for single-phase panel) front of panel indicator LED's.

It is installed on a column fitted to the pump support.

Pre-calibrated pump start / stop pressure switches.

The panel can be connected to:

Float or pressure switch KIT as protection against operation without water (*) maximum pressure switch KIT (*)

(*) Optional items available on request

The units are supplied packed in a strong cardboard box with a wooden pallet and instructions/maintenance sheet complete with wiring diagram.

1 KVCX 50

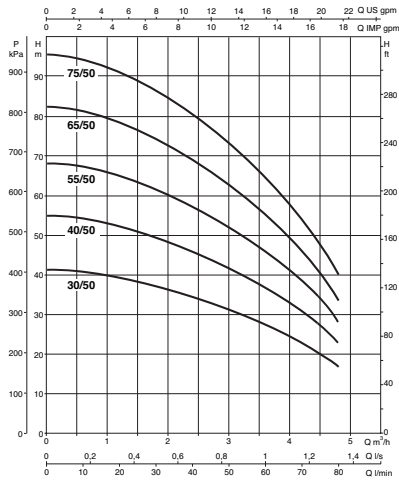

1 KVCX 80

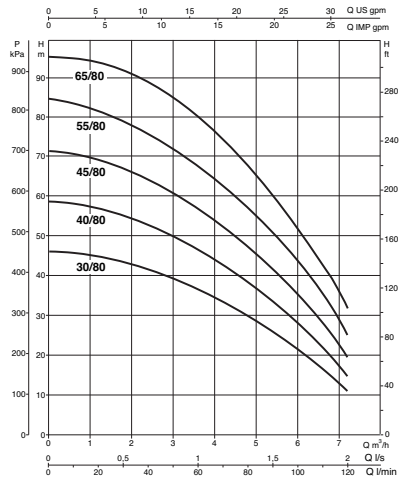

1 KVCX 120

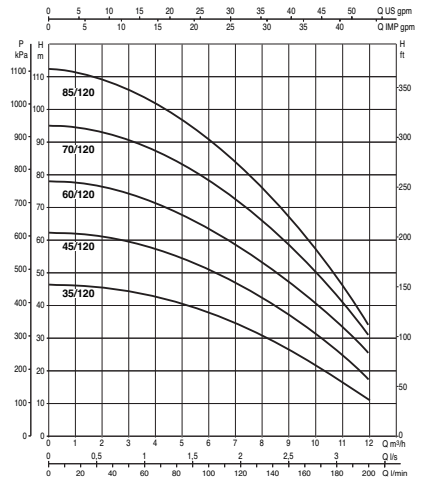

2 KVCX 50

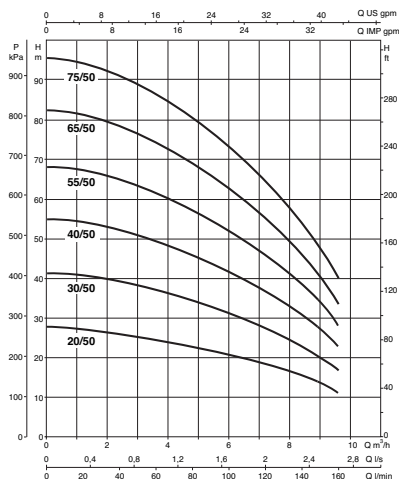

2 KVCX 80

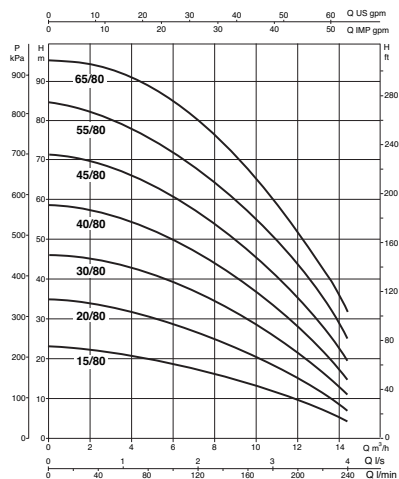

2 KVCX 120

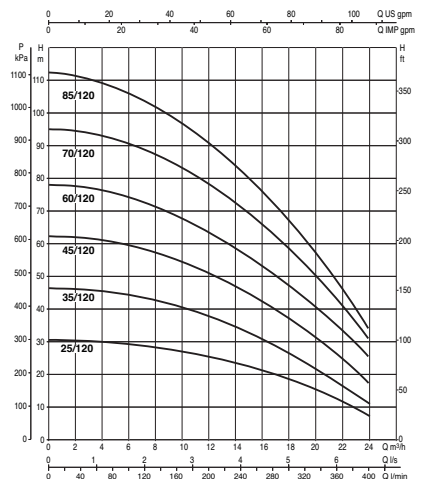

3 KVCX 50

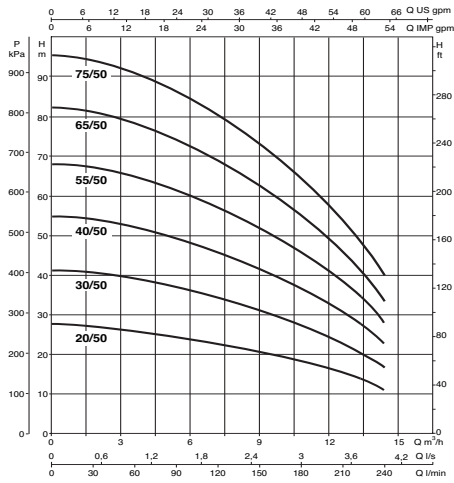

3 KVCX 80

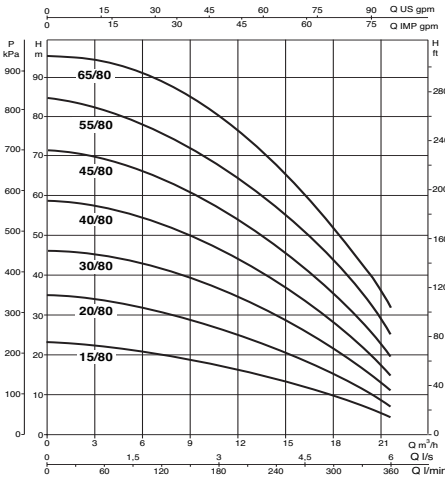

3 KVCX 120

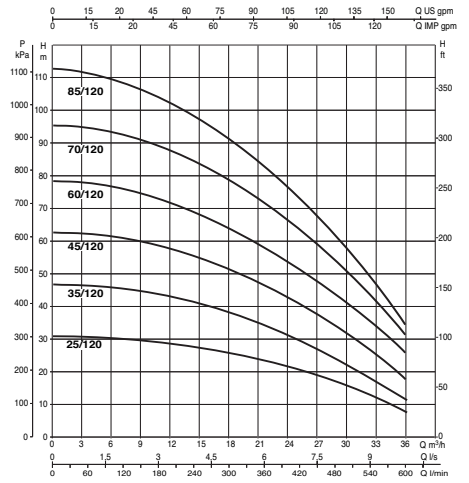

ELECTRICAL AND HYDRAULIC DATA

1 KVCX

MODEL	VOLTAGE 50 Hz	P2 NOMINAL		I _n A	Q m³/h	MAX PRESSURE OBTAINABLE BAR	PRESSURE SWITCH SETTING IN BAR
		kW	HP				
GRUPPI 1KVCX 30/50 M	1x 220-240 v	0,55	0,75	4	4,5 - 1	4	2,5 - 3,5
GRUPPI 1KVCX 30/50 T	3x 400 v	0,55	0,75	1,4	4,5 - 1	4	2,5 - 3,5
GRUPPI 1KVCX 40/50 M	1x 220-240 v	0,8	1,1	5,6	4,5 - 1	5,2	4 - 5
GRUPPI 1KVCX 40/50 T	3x 400 v	0,8	1,1	2,2	4,5 - 1	5,2	4 - 5
GRUPPI 1KVCX 55/50 M	1x 220-240 v	1	1,36	6,4	4,5 - 1	6,5	5 - 6
GRUPPI 1KVCX 55/50 T	3x 400 v	1	1,36	2,6	4,5 - 1	6,5	5 - 6
GRUPPI 1KVCX 65/50 M	1x 220-240 v	1,1	1,5	7,4	4,5 - 1	8	6,5 - 7,5
GRUPPI 1KVCX 65/50 T	3x 400 v	1,1	1,5	3,1	4,5 - 1	8	6,5 - 7,5
GRUPPI 1KVCX 75/50 M	1x 220-240 v	1,5	2	9	4,5 - 1	9	7,5 - 8,5
GRUPPI 1KVCX 75/50 T	3x 400 v	1,5	2	3,6	4,5 - 1	9	7,5 - 8,5
GRUPPI 1KVCX 30/80 M	1x 220-240 v	0,8	1,1	5,6	7 - 2	4,5	3 - 4
GRUPPI 1KVCX 30/80 T	3x 400 v	0,8	1,1	2,2	7 - 2	4,5	3 - 4
GRUPPI 1KVCX 40/80 M	1x 220-240 v	1	1,36	6,5	7 - 2	5,5	4 - 5
GRUPPI 1KVCX 40/80 T	3x 400 v	1	1,36	2,6	7 - 2	5,5	4 - 5
GRUPPI 1KVCX 45/80 M	1x 220-240 v	1,1	1,5	7,4	7 - 2	6,8	5 - 6
GRUPPI 1KVCX 45/80 T	3x 400 v	1,1	1,5	3,1	7 - 2	6,8	5 - 6
GRUPPI 1KVCX 55/80 M	1x 220-240 v	1,5	2	9	7 - 2	8	6 - 7
GRUPPI 1KVCX 55/80 T	3x 400 v	1,5	2	3,6	7 - 2	8	6 - 7
GRUPPI 1KVCX 65/80 T	3x 400 v	2,2	3	4	7 - 2	9,2	7 - 8
GRUPPI 1KVCX 35/120 M	1x 220-240 v	1,1	1,5	7,4	11 - 2	4,5	3 - 4
GRUPPI 1KVCX 35/120 T	3x 400 v	1,1	1,5	3,5	11 - 2	4,5	3 - 4
GRUPPI 1KVCX 45/120 M	1x 220-240 v	1,85	2,5	12	11 - 2	6	4,5 - 5,5
GRUPPI 1KVCX 45/120 T	3x 400 v	1,85	2,5	4,6	11 - 2	6	4,5 - 5,5
GRUPPI 1KVCX 60/120 T	3x 400 v	2,2	3	5,4	11 - 2	7,5	5,5 - 6,5
GRUPPI 1KVCX 70/120 T	3x 400 v	3	4	6,8	11 - 2	9	7 - 8
GRUPPI 1KVCX 85/120 T	3x 400 v	3	4	7,8	11 - 2	10,5	9 - 10

2 KVCX

MODEL	VOLTAGE 50 Hz	P2 NOMINAL		In A	Q m³/h	MAX PRESSURE OBTAINABLE BAR	PRESSURE SWITCH SETTING IN BAR
		kW	HP				
2KVCX 30/50 M	1x 220-240 v	2x 0,55	2x 0,75	2x 4	9 - 1	4	2 - 3,5
2KVCX 30/50 T	3x 400 v	2x 0,55	2x 0,75	2x 1,4	9 - 1	4	2 - 3,5
2KVCX 40/50 M	1x 220-240 v	2x 0,8	2x 1,1	2x 5,6	9 - 1	5,2	3,5 - 5
2KVCX 40/50 T	3x 400 v	2x 0,8	2x 1,1	2x 2,2	9 - 1	5,2	3,5 - 5
2KVCX 55/50 M	1x 220-240 v	2x 1	2x 1,36	2x 6,4	9 - 1	6,5	4,5 - 6
2KVCX 55/50 T	3x 400 v	2x 1	2x 1,36	2x 2,6	9 - 1	6,5	4,5 - 6
2KVCX 65/50 M	1x 220-240 v	2x 1,1	2x 1,5	2x 7,4	9 - 1	8	6 - 7,5
2KVCX 65/50 T	3x 400 v	2x 1,1	2x 1,5	2x 3,1	9 - 1	8	6 - 7,5
2KVCX 75/50 M	1x 220-240 v	2x 1,5	2x 2	2x 9	9 - 1	9	7 - 8,5
2KVCX 75/50 T	3x 400 v	2x 1,5	2x 2	2x 3,6	9 - 1	9	7 - 8,5
2KVCX 30/80 M	1x 220-240 v	2x 0,8	2x 1,1	2x 5,6	14 - 2	4,5	2,5 - 4
2KVCX 30/80 T	3x 400 v	2x 0,8	2x 1,1	2x 2,2	14 - 2	4,5	2,5 - 4
2KVCX 40/80 M	1x 220-240 v	2x 1	2x 1,36	2x 6,5	14 - 2	5,5	3,5 - 5
2KVCX 40/80 T	3x 400 v	2x 1	2x 1,36	2x 2,6	14 - 2	5,5	3,5 - 5
2KVCX 45/80 M	1x 220-240 v	2x 1,1	2x 1,5	2x 7,4	14 - 2	6,8	4,5 - 6
2KVCX 45/80 T	3x 400 v	2x 1,1	2x 1,5	2x 3,1	14 - 2	6,8	4,5 - 6
2KVCX 55/80 M	1x 220-240 v	2x 1,5	2x 2	2x 9	14 - 2	8	5,5 - 7
2KVCX 55/80 T	3x 400 v	2x 1,5	2x 2	2x 3,6	14 - 2	8	5,5 - 7
2KVCX 65/80 T	3x 400 v	2x 2,2	2x 3	2x 4	14 - 2	9,2	6,5 - 8
2KVCX 35/120 M	1x 220-240 v	2x 1,1	2x 1,5	2x 7,4	22 - 2	4,5	2,5 - 4
2KVCX 35/120 T	3x 400 v	2x 1,1	2x 1,5	2x 3,5	22 - 2	4,5	2,5 - 4
2KVCX 45/120 M	1x 220-240 v	2x 1,85	2x 2,5	2x 12	22 - 2	6	4 - 5,5
2KVCX 45/120 T	3x 400 v	2x 1,85	2x 2,5	2x 4,6	22 - 2	6	4 - 5,5
2KVCX 60/120 T	3x 400 v	2x 2,2	2x 3	2x 5,4	22 - 2	7,5	5 - 6,5
2KVCX 70/120 T	3x 400 v	2x 3	2x 4	2x 6,8	22 - 2	9	6,5 - 8
2KVCX 85/120 T	3x 400 v	2x 3	2x 4	2x 7,8	22 - 2	10,5	8,5 - 10

3 KVCX

MODEL	VOLTAGE 50 Hz	P2 NOMINAL		In A	Q m³/h	MAX PRESSURE OBTAINABLE BAR	PRESSURE SWITCH SETTING IN BAR
		kW	HP				
3KVCX 30/50 M	1x 220-240 v	3x 0,55	3x 0,75	3x 4	13,5 - 1	4	1,5 - 3,5
3KVCX 30/50 T	3x 400 v	3x 0,55	3x 0,75	3x 1,4	13,5 - 1	4	1,5 - 3,5
3KVCX 40/50 M	1x 220-240 v	3x 0,8	3x 1,1	3x 5,6	13,5 - 1	5,2	3 - 5
3KVCX 40/50 T	3x 400 v	3x 0,8	3x 1,1	3x 2,2	13,5 - 1	5,2	3 - 5
3KVCX 55/50 M	1x 220-240 v	3x 1	3x 1,36	3x 6,4	13,5 - 1	6,5	4 - 6
3KVCX 55/50 T	3x 400 v	3x 1	3x 1,36	3x 2,6	13,5 - 1	6,5	4 - 6
3KVCX 65/50 M	1x 220-240 v	3x 1,1	3x 1,5	3x 7,4	13,5 - 1	8	5,5 - 7,5
3KVCX 65/50 T	3x 400 v	3x 1,1	3x 1,5	3x 3,1	13,5 - 1	8	5,5 - 7,5
3KVCX 75/50 M	1x 220-240 v	3x 1,5	3x 2	3x 9	13,5 - 1	9	6,5 - 8,5
3KVCX 75/50 T	3x 400 v	3x 1,5	3x 2	3x 3,6	13,5 - 1	9	6,5 - 8,5
3KVCX 30/80 M	1x 220-240 v	3x 0,8	3x 1,1	3x 5,6	21 - 2	4,5	2 - 4
3KVCX 30/80 T	3x 400 v	3x 0,8	3x 1,1	3x 2,2	21 - 2	4,5	2 - 4
3KVCX 40/80 M	1x 220-240 v	3x 1	3x 1,36	3x 6,5	21 - 2	5,5	3 - 5
3KVCX 40/80 T	3x 400 v	3x 1	3x 1,36	3x 2,6	21 - 2	5,5	3 - 5
3KVCX 45/80 M	1x 220-240 v	3x 1,1	3x 1,5	3x 7,4	21 - 2	6,8	4 - 6
3KVCX 45/80 T	3x 400 v	3x 1,1	3x 1,5	3x 3,1	21 - 2	6,8	4 - 6
3KVCX 55/80 M	1x 220-240 v	3x 1,5	3x 2	3x 9	21 - 2	8	5 - 7
3KVCX 55/80 T	3x 400 v	3x 1,5	3x 2	3x 3,6	21 - 2	8	5 - 7
3KVCX 65/80 T	3x 400 v	3x 2,2	3x 3	3x 4	21 - 2	9,2	6 - 8
3KVCX 35/120 M	1x 220-240 v	3x 1,1	3x 1,5	3x 7,4	33 - 2	4,5	2 - 4
3KVCX 35/120 T	3x 400 v	3x 1,1	3x 1,5	3x 3,5	33 - 2	4,5	2 - 4
3KVCX 45/120 M	1x 220-240 v	3x 1,85	3x 2,5	3x 12	33 - 2	6	3,5 - 5,5
3KVCX 45/120 T	3x 400 v	3x 1,85	3x 2,5	3x 4,6	33 - 2	6	3,5 - 5,5
3KVCX 60/120 T	3x 400 v	3x 2,2	3x 3	3x 5,4	33 - 2	7,5	4,5 - 6,5
3KVCX 70/120 T	3x 400 v	3x 3	3x 4	3x 6,8	33 - 2	9	6 - 8
3KVCX 85/120 T	3x 400 v	3x 3	3x 4	3x 7,8	33 - 2	10,5	8 - 10

DIMENSIONS AND WEIGHTS

1 KVCX

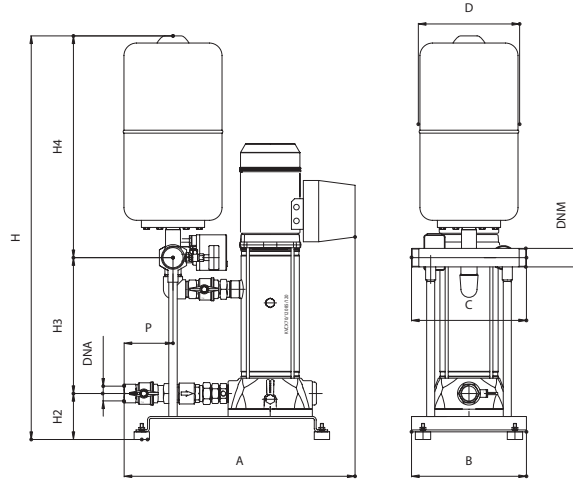

2 KVCX

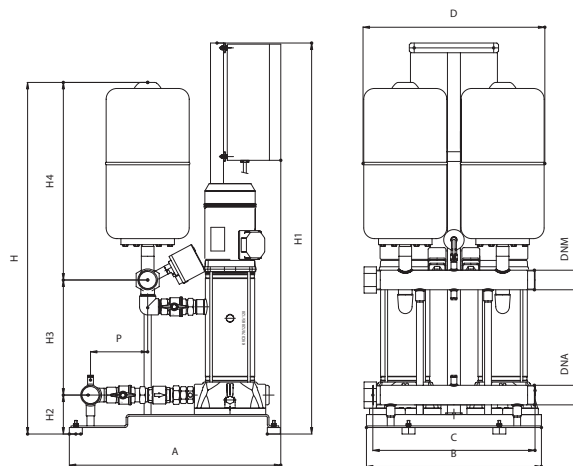

3 KVCX

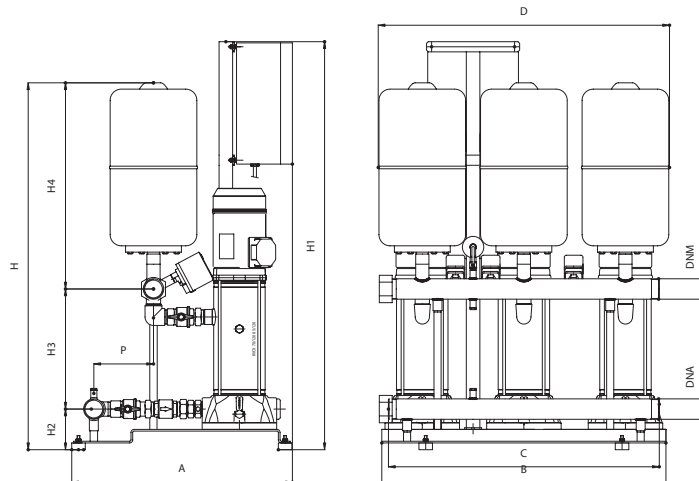

MODEL	A	B	C	D	P	H	H1	H2	H3	H4	Ø MANIFOLD		WEIGHT Kg	
											DNA (suction)	DNM (delivery)	Single-Phase	Three-Phase
1KVCX 30/50	630	300	300	260	130	940	-	120	210	610	1" 1/4	1" 1/2	26	26
1KVCX 40/50	630	300	300	260	130	995	-	120	265	610	1" 1/4	1" 1/2	28	28
1KVCX 55/50	630	300	300	260	130	995	-	120	265	610	1" 1/4	1" 1/2	29	29
1KVCX 65/50	630	300	300	260	130	1085	-	120	355	610	1" 1/4	1" 1/2	32	32
1KVCX 75/50	630	300	300	260	130	1085	-	120	355	610	1" 1/4	1" 1/2	33	32
1KVCX 30/80	630	300	300	260	130	995	-	120	265	610	1" 1/4	1" 1/2	28	27
1KVCX 40/80	630	300	300	260	130	995	-	120	265	610	1" 1/4	1" 1/2	29	29
1KVCX 45/80	630	300	300	260	130	1085	-	120	355	610	1" 1/4	1" 1/2	32	32
1KVCX 55/80	630	300	300	260	130	1085	-	120	355	610	1" 1/4	1" 1/2	33	32
1KVCX 65/80	630	300	300	260	130	1185	-	120	385	610	1" 1/4	1" 1/2	-	34
1KVCX 35/120	630	300	300	260	130	940	-	120	210	610	1" 1/4	1" 1/2	32	32
1KVCX 45/120	630	300	300	260	130	995	-	120	265	610	1" 1/4	1" 1/2	44	34
1KVCX 60/120	630	300	300	260	130	995	-	120	265	610	1" 1/4	1" 1/2	-	36
1KVCX 70/120	630	300	300	260	130	1085	-	120	355	610	1" 1/4	1" 1/2	-	38
1KVCX 85/120	630	300	300	260	130	1085	-	120	355	610	1" 1/4	1" 1/2	-	39
2KVCX 30/50 M	655	540	500	560	175	940	1205	120	210	610	2"	2"	70	70
2KVCX 40/50 M	655	540	500	560	175	995	1205	120	265	610	2"	2"	74	74
2KVCX 55/50 M	655	540	500	560	175	995	1205	120	265	610	2"	2"	76	76
2KVCX 65/50 M	655	540	500	560	175	1085	1205	120	355	610	2"	2"	82	81
2KVCX 75/50 M	655	540	500	560	175	1085	1205	120	355	610	2"	2"	84	83
2KVCX 30/80 M	655	540	500	560	175	995	1205	120	265	610	2"	2"	73	73
2KVCX 40/80 M	655	540	500	560	175	995	1205	120	265	610	2"	2"	76	76
2KVCX 45/80 M	655	540	500	560	175	1085	1205	120	355	610	2"	2"	82	82
2KVCX 55/80 M	655	540	500	560	175	1085	1205	120	355	610	2"	2"	84	82
2KVCX 65/80 T	655	540	500	560	175	1185	1205	120	385	610	2"	2"	-	85
2KVCX 35/120 M	655	540	500	560	175	940	1205	120	210	610	2"	2"	82	82
2KVCX 45/120 M	655	540	500	560	175	995	1205	120	265	610	2"	2"	86	86
2KVCX 60/120 T	655	540	500	560	175	995	1205	120	265	610	2"	2"	-	90
2KVCX 70/120 T	655	540	500	560	175	1085	1205	120	355	610	2"	2"	-	94
2KVCX 85/120 T	655	540	500	560	175	1085	1205	120	355	610	2"	2"	-	95
3KVCX 30/50	655	840	800	860	175	940	1205	120	210	610	2" 1/2	2" 1/2	109	109
3KVCX 40/50	655	840	800	860	175	995	1205	120	265	610	2" 1/2	2" 1/2	115	115
3KVCX 55/50	655	840	800	860	175	995	1205	120	265	610	2" 1/2	2" 1/2	119	119
3KVCX 65/50	655	840	800	860	175	1085	1205	120	355	610	2" 1/2	2" 1/2	128	127
3KVCX 75/50	655	840	800	860	175	1085	1205	120	355	610	2" 1/2	2" 1/2	132	130
3KVCX 30/80	655	840	800	860	175	995	1205	120	265	610	2" 1/2	2" 1/2	115	114
3KVCX 40/80	655	840	800	860	175	995	1205	120	265	610	2" 1/2	2" 1/2	119	119
3KVCX 45/80	655	840	800	860	175	1085	1205	120	355	610	2" 1/2	2" 1/2	128	128
3KVCX 55/80	655	840	800	860	175	1085	1205	120	355	610	2" 1/2	2" 1/2	131	128
3KVCX 65/80	655	840	800	860	175	1185	1205	120	385	610	2" 1/2	2" 1/2	-	133
3KVCX 35/120	655	840	800	860	175	940	1205	120	210	610	2" 1/2	2" 1/2	128	128
3KVCX 45/120	655	840	800	860	175	995	1205	120	265	610	2" 1/2	2" 1/2	134	134
3KVCX 60/120	655	840	800	860	175	995	1205	120	265	610	2" 1/2	2" 1/2	-	140
3KVCX 70/120	655	840	800	860	175	1085	1205	120	355	610	2" 1/2	2" 1/2	-	146
3KVCX 85/120	655	840	800	860	175	1085	1205	120	355	610	2" 1/2	2" 1/2	-	148